

FLANGES

BLANK FLANGES NP 25 NP 40 AND NP 64

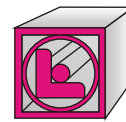

G.OGRINC
katalog strojne
instalacije

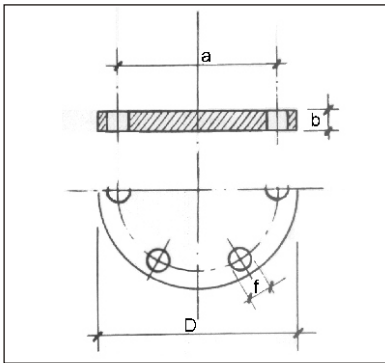

Art. 008.6094 NP 25 UNI 6094/67

Art. 008.6095 NP 40 UNI 6095/67

Art. 008.6096 NP 64 UNI 6096/67

Execution: ASTMA105 steel - completely turned - drilled as table
- phonometric lined sealing surface.

Diameters: ND 10 ÷ ND 500 (Art. 008.6094 and Art. 008.6095)
ND 10 ÷ ND 400 (Art. 008.6096 NP 64 UNI 6096/67)

On request: FE 410 execution.

Dimensions and weights

ND	UNI 6094/67 NP 25						UNI 6095/67 NP 40						UNI 6096/67 NP 64					
	Diam. D	C.line a	Thick. b	Holes n°	Diam. f	Appr. weight Kg.	Diam. D	C.line a	Thick. b	Holes n°	Diam. f	Appr. weight Kg.	Diam. D	C.line a	Thick. b	Holes n°	Diam. f	Appr. weight Kg.
10	90	60	16	4	14	0.720	90	60	16	4	14	0.720	100	70	20	4	14	1.040
15	95	65	16	4	14	0.810	95	65	16	4	14	0.810	105	75	20	4	14	1.160
20	105	75	18	4	14	1.140	105	75	18	4	14	1.140	130	90	22	4	18	1.960
25	115	85	18	4	14	1.380	115	85	18	4	14	1.380	140	100	24	4	18	2.530
32	140	100	18	4	18	2.030	140	100	18	4	18	2.030	155	110	24	4	22	3.060
40	150	110	18	4	18	2.350	150	110	18	4	18	2.350	170	125	26	4	22	3.950
50	165	125	20	4	18	3.200	165	125	20	4	18	3.200	180	135	26	4	22	4.500
65	185	145	22	8	18	4.290	185	145	22	8	18	4.290	205	160	26	8	22	5.680
80	200	160	24	8	18	5.530	200	160	24	8	18	5.530	215	170	28	8	22	6.840
100	235	190	24	8	22	7.590	235	190	24	8	22	7.590	250	200	30	8	25	10.-
125	270	220	26	8	25	10.800	270	220	26	8	25	10.800	295	240	34	8	30	15.900
150	300	250	28	8	25	14.700	300	250	28	8	25	14.700	345	280	36	8	33	23.300
175	330	280	28	12	25	17.500	350	295	32	12	30	22.-	375	310	40	12	33	30.200
200	360	310	30	12	25	22.600	375	320	34	12	30	27.200	415	345	42	12	36	39.-
250	425	370	32	12	30	33.500	450	385	38	12	33	44.400	470	400	46	12	36	54.600
300	485	430	34	16	30	46.300	515	450	42	16	33	64.200	530	460	52	16	36	80.500
350	555	490	38	16	33	68.100	580	510	46	16	36	89.500	600	525	56	16	39	112.-
400	620	550	40	16	36	89.700	660	585	50	16	39	127.-	670	585	60	16	42	151.-
450	670	600	42	20	36	109.-	685	610	52	20	39	141.-	-	-	-	-	-	-
500	730	660	44	20	36	137.-	755	670	52	20	42	172.-	-	-	-	-	-	-

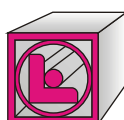

G.OGRINC d.o.o.

Tel.01 361 50 44, Fax.01 361 16 00, e-pošta.gogrinc@siol.net, spleť.www.g-ogrinc.si

