

# FLANGES

## PLATE FLANGES NP 10 UNI 2277/67

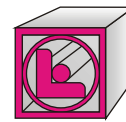

G.OGRINC  
katalog strojne  
instalacije

Art. 008.2277

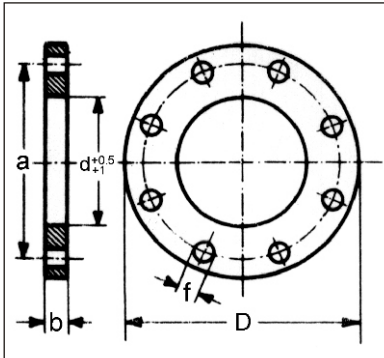

**Execution:** ASTM A105 steel - inside and on the contact surface turned - drilled as table - phonometric lines - overlap welding.

**Diameters:** ND 10 ÷ ND 1000

**On request:** raised face according to UNI 2229 - outside turned - FE 410 construction.

### Dimensions and weights

ND	FLANGE			DRILLING				Approx. weight Kg.
	Outside diameter D	Inside diameter d DIN	ISO	Thickness b	Holes n°	Diameter f	Center line a	
10	90	14	18	12	4	14	60	0.520
15	95	21	22	12	4	14	65	0.660
20	105	26	28	14	4	14	75	0.820
25	115	31	34	14	4	14	85	1.010
32	140	39	43	16	4	18	100	1.630
40	150	45	49	16	4	18	110	1.850
50	165	58	62	18	4	18	125	2.460
65	185	77	77	18	4	18	145	3.-
80	200	90	90	20	4	18	160	3.610
100	220	109	116	22	8	18	180	4.400
125	250	135	141	24	8	18	210	5.920
150	285	161	170	24	8	22	240	7.170
175	315	196	196	26	8	22	270	9.200
200	340	221	221	26	8	22	295	10.100
250	395	269	275	28	12	22	350	12.900
300	445	326	326	28	12	22	400	15.-
350	505	371	358	30	16	22	460	22.-
400	565	422	409	32	16	25	515	28.-
450	615	460	460	32	20	25	565	33.-
500	670	510	510	34	20	25	620	41.-
600	780	612	612	36	20	30	725	53.-
700	895	714	714	38	24	30	840	65.-
800	1015	816	816	40	24	33	950	88.-
900	1115	917	917	42	28	33	1050	100.-
1000	1230	1020	1020	44	28	36	1160	128.-

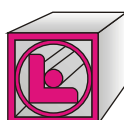

G.OGRINC d.o.o.

Tel.01 361 50 44, Fax.01 361 16 00, e-pošta.gogrinc@siol.net, spleť.www.g-ogrinc.si

VA PO RU SA