

FLANGES

WELDING NECK FLANGES NP 6 UNI 2280/67

Art. 008.2280

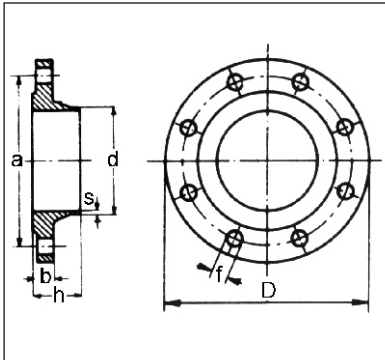

Execution: ASTMA105 steel - inside and on welding relief turned - drilled as table - sealing raised surface according to UNI 2229 - butt welding.

Diameters: ND 10 ÷ ND 2000

On request: outside turned.

Dimensions and weights

ND	FLANGE			DRILLING						Approx. weight Kg.
	Outside diameter D	Inside diam. DIN	Inside diam. ISO	Thickness b	Thickness s	Height h	Holes n°	Diameter f	Center line a	
10	75	14	18	12	2.3	28	4	11	50	0.390
15	80	21	22	12	2.5	30	4	11	55	0.450
20	90	26	28	14	2.5	32	4	11	65	0.660
25	100	31	34	14	2.8	35	4	11	75	0.830
32	120	39	43	14	3	35	4	14	90	1.160
40	130	45	49	14	3	38	4	14	100	1.380
50	140	58	62	14	3.5	38	4	14	110	1.560
65	160	77	77	14	3.5	38	4	14	130	1.950
80	190	90	90	16	3.7	42	4	18	150	3.070
100	210	109	116	16	3.7	45	4*	18	170	3.560
125	240	135	141	18	4	48	8	18	200	4.800
150	265	161	170	18	5	48	8	18	225	5.520
175	295	196	196	20	5	52	8	18	255	7.220
200	320	221	221	20	5	55	8	18	280	8.160
250	375	269	275	22	5.5	60	12	18	335	11.100
300	440	326	326	22	6	62	12	22	395	14.800
350	490	371	358	22	6.5	62	12	22	445	19.500
400	540	422	409	22	7	65	16	22	495	22.500
450	595	460	460	22	7.3	65	16	22	550	25.-
500	645	511	511	24	7.3	68	20	22	600	30.500
600	755	612	612	24	7.3	70	20	25	705	38.-
700	860	714	714	24	9	70	24	25	810	46.-
800	975	816	816	24	9	70	24	30	920	55.-
900	1075	917	917	26	9	70	24	30	1020	65.-
1000	1175	1020	1020	26	9	70	28	30	1120	71.-
1200	1405	1224	1224	28	9	90	32	33	1340	108.-
1400	1630	1424	1424	32	9	90	36	36	1560	153.-
1600	1830	1624	1624	34	11	90	40	36	1760	189.-
1800	2045	1824	1824	36	11	100	44	39	1970	239.-
2000	2265	2024	2024	38	12	110	48	42	2180	308.-

*For oil conveying pipes, the flange have 8 holes.

