

# BALL VALVE SPLIT BODY TYPE

## Full bore stainless steel body and ball NP 16

Art. 037.7610

**Execution:** body, ring, ball and pivot AISI 316/CF 8 stainless steel - PTFE ball gasket, pivot washer and pivot gasket - viton O-Ring - PVC covered steel lever - lever body ND 150÷ ND 200 cast iron GG 25 - full bore - flanged ends NP 16.

**Diameters:** ND 15 ÷ ND 200

Max pressure 16 bar

Working temperature -20°C +160°C

**Employments:** general liquids - low pressure sature steam.

**On request:** 304 stainless steel execution - particular seals - installation of pneumatic actuator simple or double effect (see chapter "L") - electric motorization.

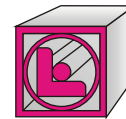

G.OGRINC  
katalog strojne  
instalacije

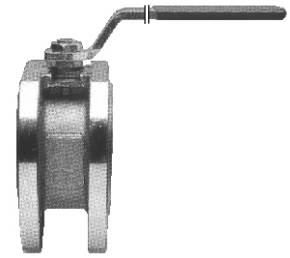

Art. 037.7610

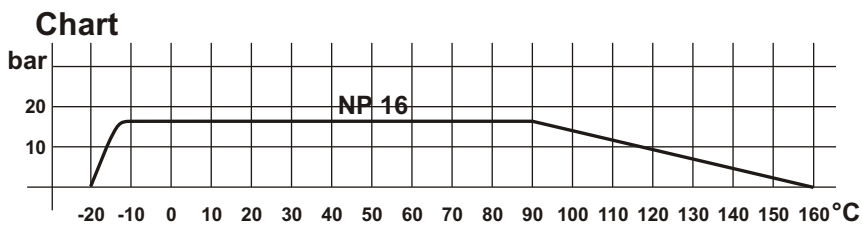

### Sizes

ND	D	Y	Z	L	R	P	A	E	F	KV	NP
15	90	65	4xM12	35	130	63	46	10	7	16.3	16
20	100	75	4xM12	40	130	67	51	10	7	29.5	16
25	110	85	4xM12	46	175	78	59	12	8	43	16
32	130	100	4xM16	54	175	83	64	12	8	89	16
40	150	110	4xM16	63.5	250	100	76	16	10	230	16
50	165	125	4xM16	82	250	107	86	16	10	265	16
65	185	145	4xM16	103	320	125	104	20	14	540	16
80	200	160	8xM16	122	320	136	113	20	14	873	16
100	220	180	8xM16	152	380	156.5	136	24	18	1390	16
125	250	210	8xM16	196	380	178.5	158	24	18	1707	16
150	285	240	8xM20	232	700	237	201	42	30	2024	16
200	340	295	12xM20	317	700	280	244	42	30	2720	16

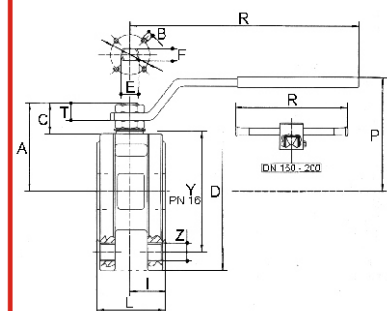

Sec.Art. 037.7610

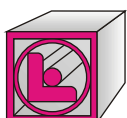

G.OGRINC d.o.o.

Tel.01 361 50 44, Fax.01 361 16 00, e-pošta.gogrinc@siol.net, splet.www.g-ogrinc.si

